

Rules for Building Construction or Alteration: Rural Residential Zone

Tasman Resource Management Plan (the “TRMP”)

Summary Guide No. 5

Current: May 2020

The following is a **summary** of Tasman Resource Management Plan (**TRMP**) provisions for building construction or alteration in the Rural Residential Zone.

The TRMP specifies, through its rules, whether an activity is permitted (meaning you can do it as of right), or whether it requires a resource consent. For this guide, only the **Permitted** Activity standards are listed.

For activities that require resource consent, the TRMP uses RMA prescribed categories that become increasingly more stringent in terms of assessment criteria. The categories used within the relevant TRMP Chapters are Controlled, Restricted Discretionary, Discretionary, Non-Complying and Prohibited Activities. If you do need a resource consent, check with Council’s duty planner for the level of information you will need to provide with a resource consent application.

A proposed activity may also be subject to additional standards and rules for other aspects of the development (such as access formation and parking requirements). In addition to standards and consents required under the Resource Management Act, the proposed activity may also need building consent, licences and permits under other legislation such as the Building and Health Acts.



1. Permitted Activities

Buildings are permitted provided there is no more than one dwelling on a site and all buildings meet the following requirements: [Note that a dwelling in the Rural Residential Zone (but not Milnthorpe) can include two self-contained housekeeping units in one building provided one unit measures no more than 60m².]

- a. The **total area** of all buildings on a site, except greenhouses, is no more than 20% of the net site area or a maximum of 600m², whichever is the smaller.
- b. A **sleepout** is no more than 36m² in area, and must be no more than 20 metres from the principal dwelling.
- c. **Height** is limited to 7.5 metres above natural ground level but buildings on hills with a ridgeline identified on the planning maps are to be no higher than the level of the ridgeline.

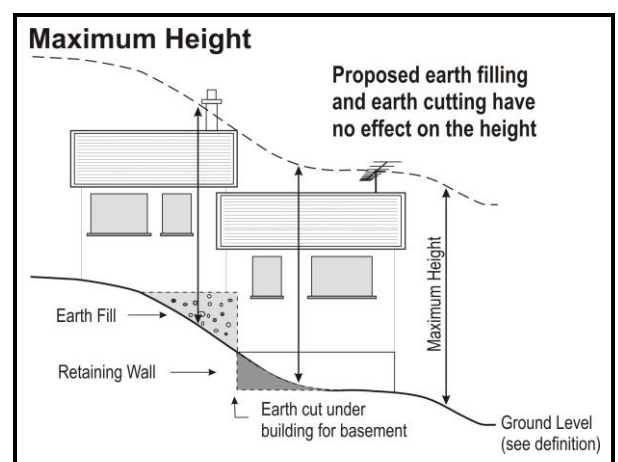

- d. **Building setbacks** are at least:
- 10 metres from road boundaries and 5 metres from other property boundaries;
 - 20 metres from the margins of lakes and from Open Space, Recreation and Conservation zones;
 - 8 metres from the banks of rivers with a bed less than 5 metres wide;
 - 20 metres from the banks of rivers with a bed greater than 5 metres wide;
 - 30 metres from the road boundary for any building forming part or all of a rural selling place;
 - 30 metres from a plantation forest;
 - 32 metres from the centre line of any electricity transmission line in the Richmond East Development Area;
 - 10 metres from internal boundaries in the case of buildings housing livestock;
 - 30 metres from a road boundary for rural selling place buildings
 - as specified from Ruby Bay ridgeline.
- e. **Dwellings and habitable buildings** are set back at least:
- 30 metres from a boundary where that boundary is to the Rural 1, Rural 2 or Rural 3 zone;
 - 130 metres from any building or enclosure that houses poultry on an existing, lawfully established intensive livestock farm which is a poultry farm on or before 30 January 2016.
- f. A dwelling is set back at least 500 metres from an existing **quarry site** that disturbs the land more than 50m³ in any 12-month period.
- g. Where the site adjoins a Residential Zone, buildings must comply with **daylight admission angles** on all boundaries adjoining the Residential Zone. Daylight admission angles are constructed from any point 2.5 metres above ground level on relevant boundaries, then at an angle across the site depending on the direction the boundary faces. For example, the angle is 45 degrees for north-facing boundaries, 35 degrees for east and west-facing boundaries and 25 degrees for south-facing boundaries. No building can project beyond the daylight admission angles, although the TRMP includes exceptions for gable ends and alternatives for a site on a south-facing slope.

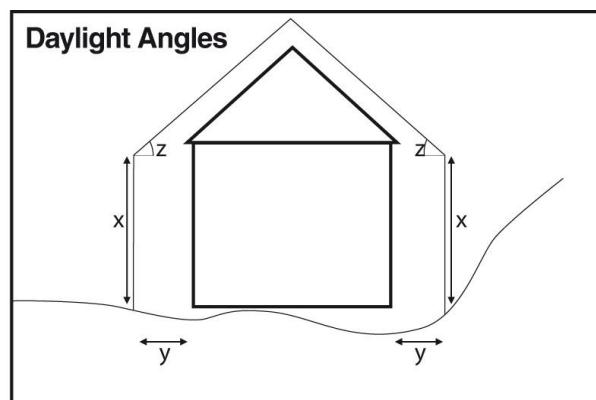

x = 2.5 metres up from any point on side and rear boundaries
y = distance the external wall is from the property boundary
z = the daylight angle between 25 and 45 degrees depending on the direction the boundary faces

- h. **Domestic Water Supply** - A dwelling not connected to a reticulated water supply is supplied with a reliable and potable supply of water (rain, ground or surface) and, where the water is stored on site, there is at least 23,000 litres of storage.
- i. **Fire Risk Management** - A dwelling not connected to a reticulated water supply that has water mains fitted with fire hydrants no more than 135 metres from the dwelling must either be provided with:
- provided with a home fire sprinkler system that is fitted with a reliable year-round supply; or
 - a water supply (either 45,000 litres stored water or a flow of 25 litres per second for 30 minutes) located between 6 and 90 metres from the dwelling and accessible to fire-fighting equipment.
- j. In the Mapua and Waimea Rural Residential zones, a dwelling is connected to **water reticulation** where available and has a **rainwater collection** system used for toilet flushing.
- k. Except in the Mapua and Waimea Rural Residential zones, there is an adequate area on site for domestic **wastewater disposal**. Mapua and Waimea Rural Residential zones not connected to wastewater reticulation will require a discharge permit for on-site wastewater disposal.

- i. Any **new residential activity** (such as a sleepout or dwelling), if located within 300 metres of a frost protection device that is likely to exceed specified noise limits, is located, orientated and constructed to ensure that bedroom and living rooms achieve an indoor design sound level of 30 dBA L_{eq} and 45 dBA L_{max} from permitted noise levels

3. Special Area Rules

Rural Residential Zone buildings must also meet all of the relevant Chapter 18 Special Area rules, for example:

- a. **Quarry Area** - A new dwelling or residential activity requires a resource consent.
- b. **Residential Activity Restriction Area** - Dwellings or residential activities require resource consent if they are at least 500 metres from a working quarry which disturbs the land more than 50m³ in any 12-month period.
- c. **Coastal Risk Area** – Only relocatable and non-habitable buildings are permitted.
- d. **Coastal Environment Area** - Extensions to existing buildings are permitted if they do not increase the ground floor area by more than 50%; reduce the existing setback from MHWS; or increase the existing height.
The activity requires a resource consent if the above standards cannot be met, and resource consent conditions will include a requirement that the external colourings be recessive.
- e. **Slope Instability Risk Area** - Construction or extension to a building is permitted if a geotechnical report:
 - states the building will not be subject to damage from slope instability nor contribute to damage on adjoining properties;
 - specifies any measures to be carried out to avoid damage; and
 - identifies any earthwork has an average vertical height or depth less than or equal to 1 metre.
- f. **Fault Rupture Risk Area** – Construction or alteration of a habitable building is permitted if a geotechnical/earthquake risk report identified the surface position of the active fault and buildings are set back specified distances from it (see the TRMP, Chapter 18.13 for details).

4. Flood Hazards

Provisions in Rule 16.10.3.1 prohibit:

- a. the construction or relocation of buildings over 15m² in floor area on any berm land; and
- b. habitable buildings over 10m² in floor area within 20 metres of a stop bank that is more than 1 metre high, or within 50 metres of a stop bank that is more than 2 metres high.

5. Relocated Dwellings

If any dwelling to which the above provisions apply is a relocated dwelling, then rule 16.8.3.1 or 16.8.3.2 also applies and resource consent will be required. Council will require a refundable bond in addition to other charges to ensure the dwelling's exterior is reinstated within a specified time in order to maintain the visual amenity.

6 National Environment Standard for Contaminated Soil (NES-CS)

The NES-CS contains rules that require resource consent if soil is shown to have levels of contamination above that suitable for a site that will be used for the development of a dwelling and associated residential use.

Council holds records of established orchards in the 1970s that may have been exposed to persistent pesticides such as lead, arsenic, copper and DDT resulting in pesticide residues in the soil. Before any land with areas of soil contamination is used for a residential activity, Council will require specialised soil testing as part of any resource consent application. Soil contamination may also occur by other means such as historic sheep dip sites and surrounding holding paddock, fertiliser storage sites, airstrips and bulk bins and fuel tanks. These may need resource consent and soil testing as set out within the NES-CS rules. Please seek Duty Planner advice.

7. Development and Financial Contributions

A development contribution is payable in accordance with the Development Contribution Policy set out in the Council's Long Term Plan and created under the Local Government Act 2002.

The development contribution is required to help fund District roads and infrastructural services other than reserves and community facilities. A financial contribution for reserves and community services is payable in accordance with the TRMP on all building

development other than a first dwelling on a title. You will need to refer to Section 16.5 of the TRMP for full details of the financial contributions that are payable and whether any limitations or exceptions apply.

This guide is a summary of TRMP provisions only. Do not rely on this guide to make decisions about your property. Other conditions may apply. Please see the Plan for full details or seek advice from Council staff at one of the offices listed below.

Tasman District Council

Email info@tasman.govt.nz

Website www.tasman.govt.nz

24 hour assistance

Richmond

189 Queen Street

Private Bag 4

Richmond 7050

New Zealand

Phone 03 543 8400

Murchison

92 Fairfax Street

Murchison 7007

New Zealand

Phone 03 523 1013

Motueka

7 Hickmott Place

PO Box 123

Motueka 7143

New Zealand

Phone 03 528 2022

Tākaka

78 Commercial Street

PO Box 74

Tākaka 7142

New Zealand

Phone 03 525 9972